

Active Lens: A Mass, Volume, and Energy Efficient Antenna for Space-Based Radar

Michael Grace, Bill Norvell, Kevin Higgins, Michael Gilbert
Toyon Research Corporation
75 Aero Camino, Suite A
Goleta, CA 93117 USA
Hooman Kazemi
Rockwell Scientific Company
1049 Camino Dos Rios
Thousand Oaks, CA 91360 USA

Abstract—Very large, lightweight phased array antenna apertures are highly desirable for space-based ground surveillance and tracking radars since power is limited by the mass efficiency of solar power collection and distribution systems which compete for the limited payload capability of the launch vehicle. This leads to relatively low power density apertures whose power budget can be dominated by the overhead (non-radiated) power used during the receive portion of the radar timeline.

We have developed a novel lens antenna concept to meet the extreme demands of next-generation, large-aperture space-based radar with significantly improved electrical and mechanical efficiency. The agile beam design offers better aperture efficiency over the entire field of regard compared with reflector designs and better electrical and mass efficiency than active array designs. The lens contains embedded MMIC modules that have been optimized for low power consumption on receive a significant departure from T/R modules used in airborne radar applications.

I. INTRODUCTION

In radar applications where prime power is limited but volume is not, radar designs will favor high-gain, low-power antennas. This is especially true for space-based radars for ground surveillance and tracking that must detect slow-moving targets and provide very high accuracy (<100 m) measurements, frequent measurement updates with minimal coverage gaps, and high signal-to-noise ratio to exploit feature information required for long-term tracking of targets. While this capability can be provided over limited areas with smaller apertures, covering a battlefield that extends over millions of square kilometers requires truly enormous, yet lightweight apertures.

Fig. 1 shows how the required antenna size for a side-looking antenna depends upon minimum detectable velocity, cross-range resolution, and satellite altitude. Note that the size referred to in the figure is the antenna dimension along the

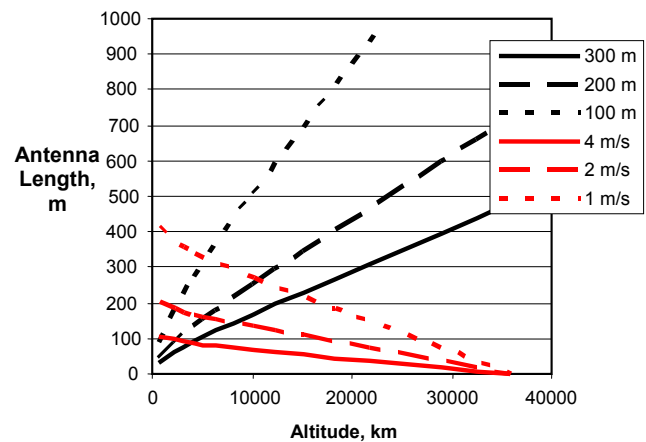

Fig. 1. Antenna size required as a function of satellite altitude, minimum detectable target velocity (red), and cross-range accuracy (black). The cross-range accuracy assumes a 1:10 beamsplit ratio.

velocity vector of the satellite. We also note that side-looking antennas are preferred for stationary target imaging using synthetic aperture techniques, and when using GMTI for minimizing clutter fold-over effects. The figure indicates that for tactical requirements of ~ 1 m/s MDV and ~ 100 -m cross-range accuracy (assuming 10:1 monopulse beamsplitting), the required antenna dimension can easily be several hundred meters.

In 1999, Toyon Research proposed an innovative new design approach to space-based radar antennas that combined compact, lightweight, rigidized-inflatable space structures and advanced reconfigurable antenna electronics. A conceptual design for an extremely large lens antenna for a tactical ground surveillance radar satellite was developed by Toyon under a seedling study for DARPA/SPO that ultimately led to the present-day Innovative SBR Antenna Technology (ISAT) Program [1]. This space-fed lens antenna (termed a passive lens) featured very low aperture areal density, high packing efficiency, and design details that minimize RF losses in the antenna. Based on this experience, Toyon has since developed a new design that features significant improvements to the lens

This work was supported by the Air Force Research Laboratory, Space Vehicles Directorate under Small Business Innovation Research Contract F29601-03-C-0048 (TPOC: Mr. Joseph Chavez, 505-846-6456).

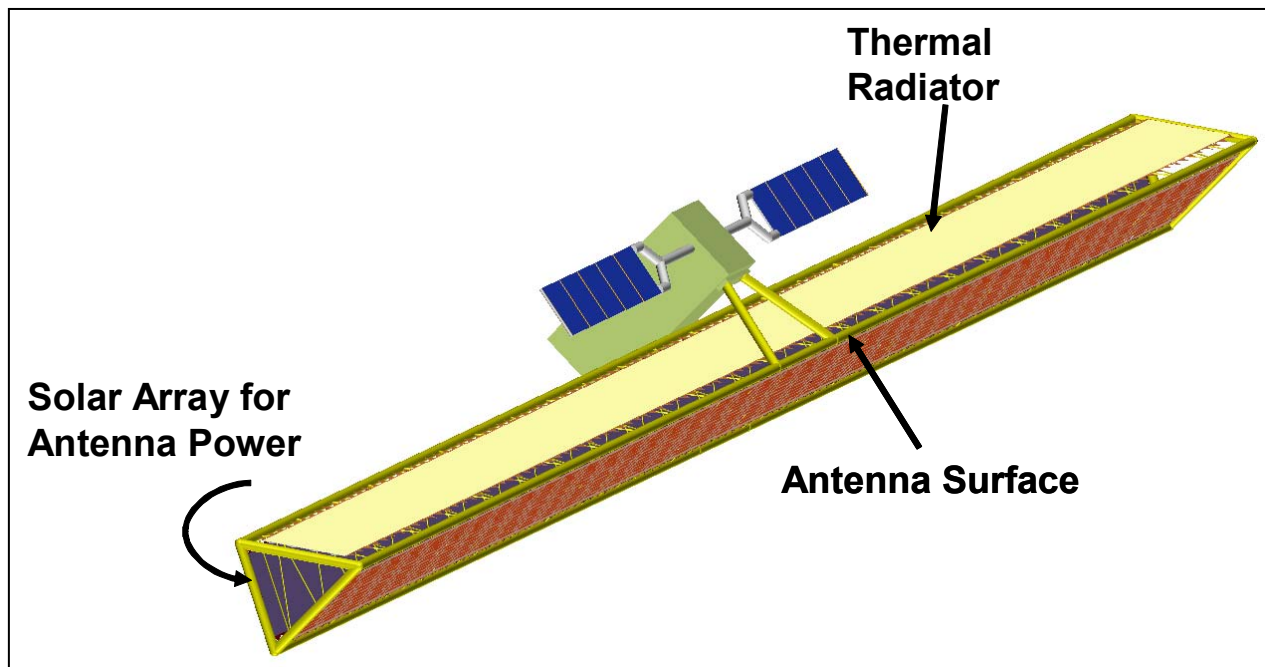

Fig. 2. Rigidized-inflatable lens antenna. Lens feed is positioned inside the cylinder closest to the apex opposite the lens face. Other faces may be used to mount solar arrays or other system components.

in terms of RF efficiency, packaging efficiency, and thermal management. The new design distributes the T/R functions across the feed and lens structure in what we call an active lens. This new design is not only superior to the passive lens design, but offers the potential of lower mass, lower cost and even greater overall efficiency than a fully active array.

II. ACTIVE LENS ANTENNA FOR TACTICAL GMTI

The shape of the antenna is based on a triangular truss structure as shown in Fig. 2. One face of the triangle is the lens and the other faces are available for mounting solar cells, thin-film batteries, and specialized thin-film surfaces for radiating heat and electrical charge into space. The frame of the truss is formed of lightweight, rigidized-inflatable fabric and membrane material arranged in a tetrahedral-truss configuration. The longerons at the apexes of the triangular truss are shown as cylinders of circular cross-section, but may be truss structures themselves.

The lens is fed from a long, narrow array positioned inside the triangular truss, close to the apex opposite the lens face. The non-steerable feed radiates onto the back side (feed side) surface of the lens. The lens is comprised of a dense array of small (nominally patch) antenna elements spaced approximately by $\lambda/4$ at X-band (1.9 cm). Each of these antenna elements on the back side (feed side) of the lens is connected via an RF circuit to another antenna element on the front side (target side) of the lens. Energy from the feed is captured by these antennas, phase-shifted, amplified, then

radiated out the front-side when the radar is transmitting and the signal path is reversed on receive. The RF circuits in the lens will be described shortly.

The antenna beam can be steered using a combination of mechanical rotation (roll) of the entire lens about its long axis and/or electronic steering. The electronic steering is achieved by a combination of phase steering and time-delay steering. The phase shifts may be applied entirely within the lens or divided between the feed and the lens. Differential time delays are applied to sections of the feed along the length of the antenna as necessary to support the radar resolution without grating lobes intersecting the Earth at the chosen altitude. Differential time delays can also be applied across the height of the antenna by using a multi-beam feed network.

Fig. 3 depicts the segmented antenna architecture for a 300-meter-long, 3-meter-high X-band lens designed for tactical GMTI at 10,000-km altitude. The scan volume in this example is a 23-degree cone (Earth subtense from 10,000 km). The choice of 2-meter-wide panels is made purely for mechanical packaging reasons and ease of fabrication. Using a simple (single elevation beam) feed limits the bandwidth of the antenna to approximately 200 MHz.

If needed to support higher bandwidth, the time-delay spacing along the antenna can be decreased and a more complex, multi-beam feed added to introduce time-delay steering across the short dimension of the antenna as shown in Fig. 4. The figure shows a Blass network providing two beams

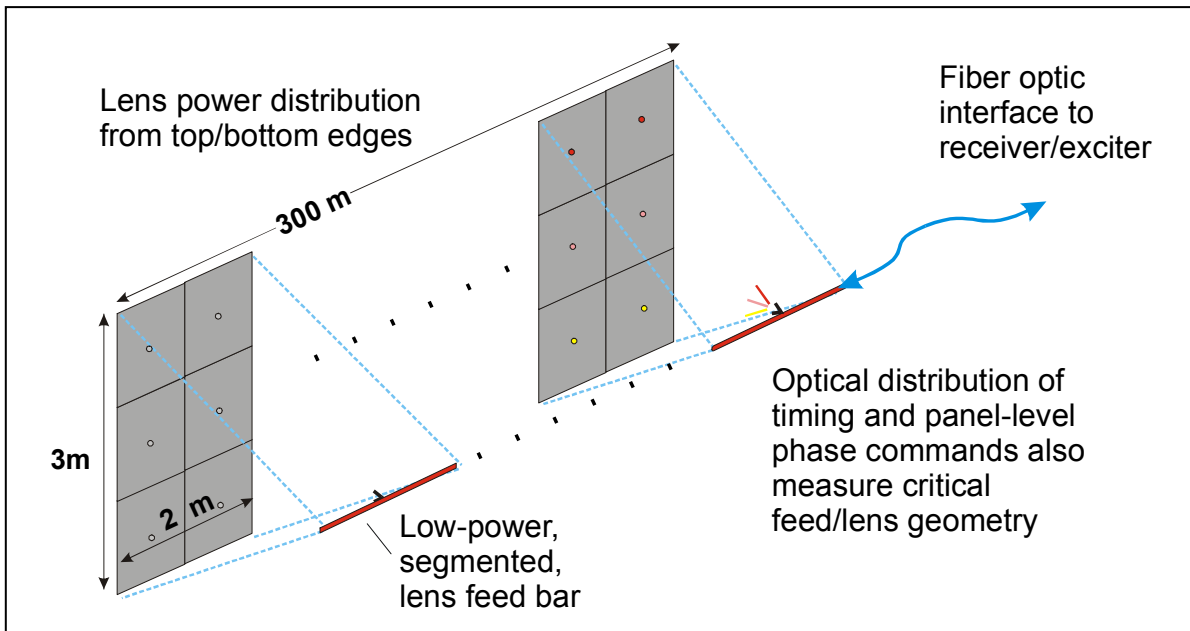

Fig. 3. MEO lens configuration with single elevation beam feed supports 200 MHz bandwidth.

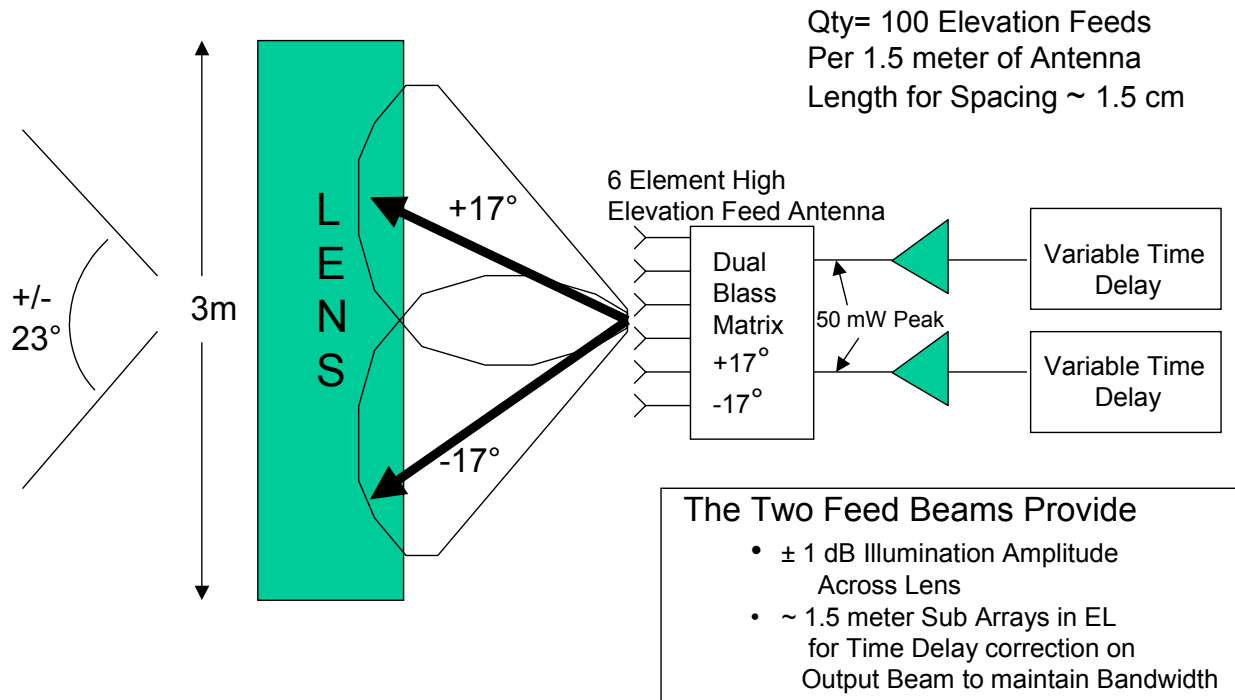

Fig. 4. Two vertical beam feed network provides 380 MHz of bandwidth and uniform (± 1 dB) feed illumination of the lens.

in elevation (1.5-meter spacing). If the spacing along the antenna is also chosen to be 1.5 meters, then the bandwidth is increased to approximately 380 MHz. This more complex feed network also has the benefit of providing a more uniform lens illumination function which increases the efficiency of the

lens by driving all the power amplifiers into saturation without over-driving some and under-driving others.

The RF signals are synthesized in a centralized receiver/exciter but are distributed to/from each subarray via

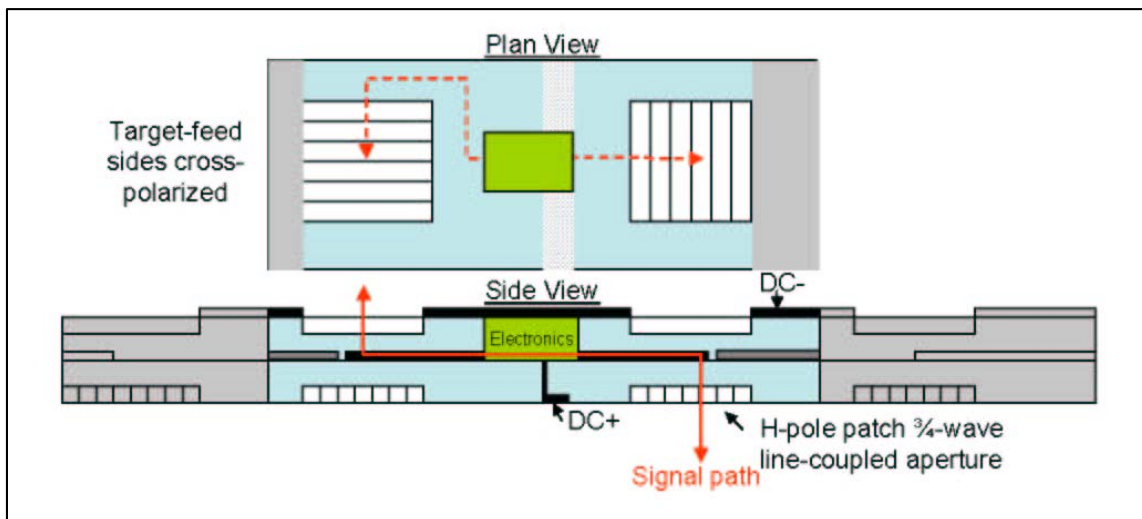

Fig. 5. Coplanar active lens construction minimizes mass and cost.

fiber optic cables. From each feed subarray, lens steering commands and timing synchronization pulses are sent via wires or free-space optics to subarray-level ASICs within the lens which control the individual T/R elements.

Fig. 5 shows a detailed picture of the lens and its components. The coplanar lens structure uses the simplest and

lowest mass lens implementation. However, the addition of another layer may be necessary to meet isolation requirements.

Gain and loss stages are distributed very carefully within the T/R module and lens. Fig. 6 shows a block diagram of the critical embedded RF circuit connecting the radiating elements on both sides of the lens. The circuit contains RF amplifiers,

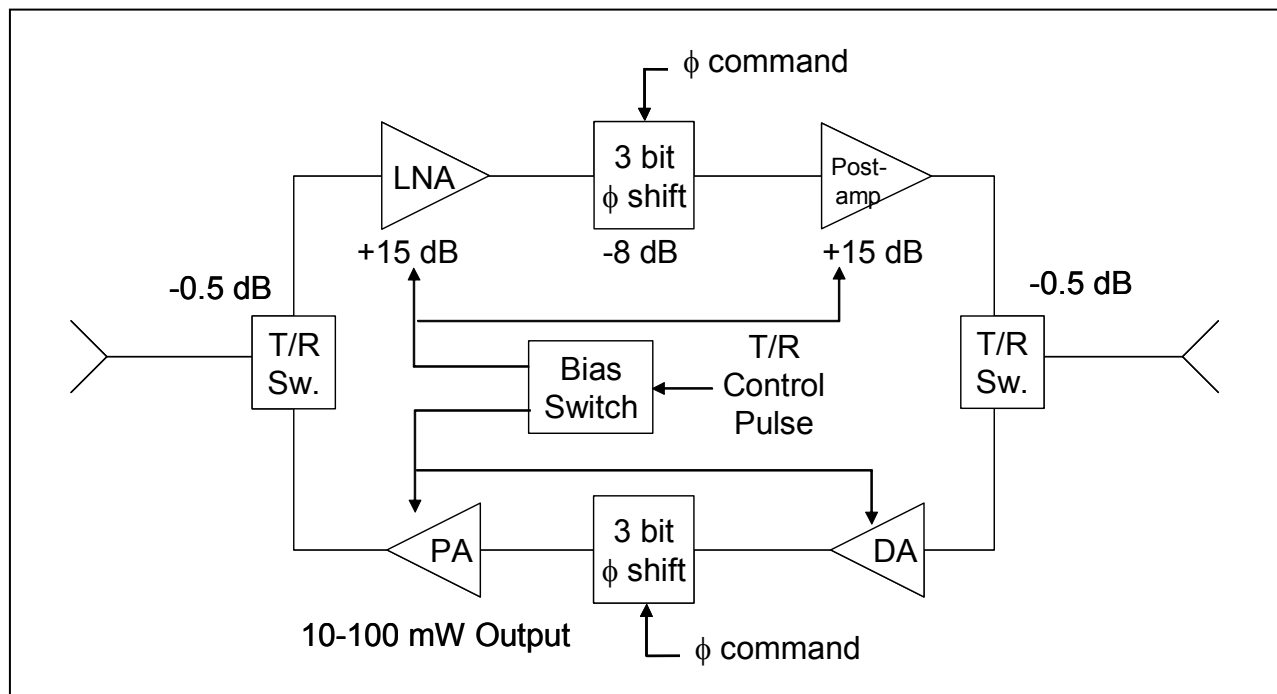

Fig. 6. Block diagram of a conceptual RF circuit connecting the antenna elements on the front- and back-sides of the lens. Gain and loss stages are staggered for efficiency and minimal noise figure degradation. T/R switches may be eliminated with PA/LNA bias control, depending on isolation requirements to be determined.

phase shifters, and switches for isolating the transmit and receive paths. For maximum efficiency and to minimize oscillation in the lens, the T/R amplifiers are gated off when the opposite function is on. Because the lens contains these amplification stages, it is termed an “active lens.” Without these amplifiers, it is termed a “passive lens.”

III. LOW POWER, HIGH EFFICIENCY T/R MODULES

A key to achieving the efficiency and power performance goals of the active lens is realizing the transmit/receive (T/R) functions in a single, high-performance integrated circuit chip. Furthermore, we have identified InP as the preferred material for these chips. A companion paper describes the features and design techniques used to produce these T/R modules [2].

In a large-aperture SBR, since each transmit element radiates only ~10-100 milliwatts at a 10% duty cycle (1-10 milliwatts average), total power consumption of the T/R module can be dominated by receive mode. The current mature technology base uses SiGe or GaAs MMIC for the X-band radar T/R cells. Using today’s T/R cell technology, a 20 dB gain LNA with 1 dB noise figure would use ~10 milliwatts and have a transmitter efficiency of ~40%. InP design can yield an equivalent LNA for << 10 milliwatts power and transmit efficiency of 60%.

IV. ADVANTAGES OF ACTIVE LENS

The advantage of the active lens over fully active arrays is that signal distribution is achieved via mass-less space-feed, which is much simpler and more efficient for large microwave antennas than waveguide, stripline, micro-strip, or other

manifolds. A common feature with active arrays is the proximity of the final transmit and first receive amplifier to the target-side antenna element. Compared with previous passive lens designs, the active lens is much more efficient at converting prime power to radiated power and also provides much better noise figure due to the reduced losses before the receiver LNA (see Fig. 7).

The active lens approach solves this problem by establishing the noise figure earlier in the RF chain. Since the phase shifter must be located in the lens for beam agility over a wide scan angle, it does not cost significantly more to include a single low-power amplification stage for both paths and T/R isolators on the same chip. There is also some benefit to the power-added efficiency (PAE) of the antenna since the low-power amplifiers eliminate combining losses of multiple high-power transistor outputs as typical in conventional high-power active-array T/R modules.

Another important benefit, especially for space applications, is improved antenna thermal management. Whereas the high-power amplifiers in the feed of the passive lens generate heat in a small area which requires removal via heat pipes, most of the heat generated in the active lens is spread over the large area of the lens so that it may be radiated without heat pipes. The lower noise figure of the active lens also requires less transmit power for the same sensitivity, so that the feed power can be reduced, thereby reducing and likely eliminating the need to actively cool the T/R modules in the feed.

Finally, the active lens offers the lowest cost possible per array element while still supporting the demanding system goals of a space-based GMTI radar. The cost per unit element

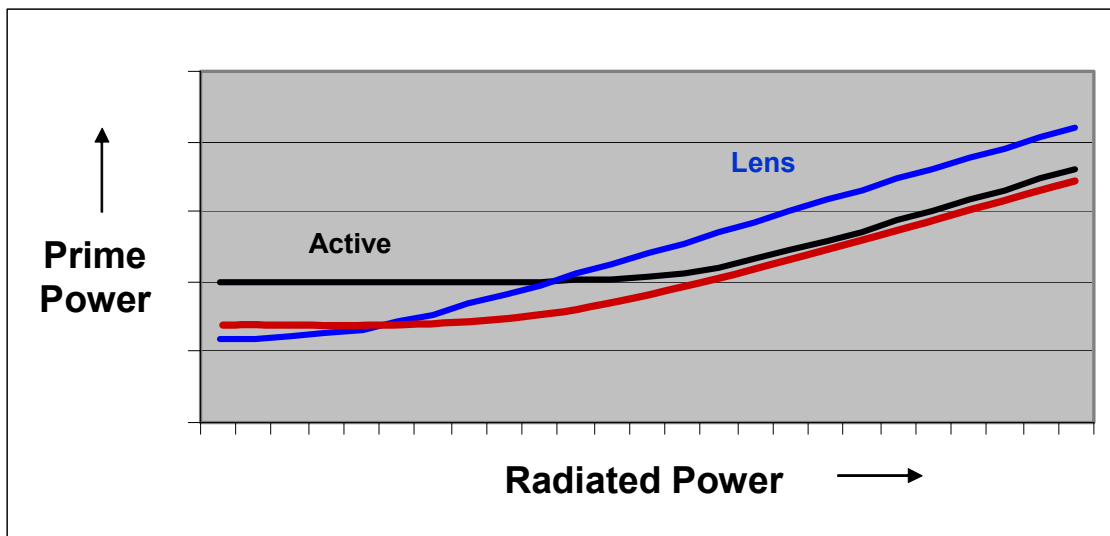

Fig. 7. Notional radiated power efficiency for passive lens (Lens), a constrained-feed active ESA (Active), and the active lens (Active Lens). At low radiated power, the Lens is most efficient due to lowest number of receivers. At low power, the Active Lens is less efficient than the passive lens, but more efficient than the Active ESA due to the greater efficiency of space feed versus constrained feed. At high radiated power, overhead power is no longer dominant and the passive lens suffers due to the losses on transmit and receive. The Active Lens and Active ESA are approximately the same.

is minimized by the single-chip design while more complex functions such as time-delay units are applied at the feed-level which has many fewer elements. More importantly, the space feed also eliminates most of the manifold distribution of the conventional corporate-fed array, reducing antenna mass and power amplification needed to overcome line losses over large aperture areas.

V. SUMMARY

We have described a novel antenna architecture for space-based ground surveillance and tracking. Because of the accuracy and minimum detectable velocity requirements, a very large, lightweight antenna design with low radiated power density is favored. Our Active Lens design features low-power, single-chip, InP T/R modules that give it much greater sensitivity compared with passive lens. The antenna's low overhead power and space feed provide a mass and overhead power advantage over a conventional active array

design. Such an Active Lens design has significant overall mass (and therefore cost) savings over competing agile-beam designs, providing an enabling technology for next-generation space-based radar systems.

ACKNOWLEDGMENT

The authors would like to acknowledge the assistance of and helpful discussions with Mr. Joe Chavez and Mr. Bob Acree of AFRL/VS. Their support is sincerely appreciated.

REFERENCES

- [1] J. Guerci, "Innovative SBR Antenna Technology Program Bidder's Conference," August 2001.
- [2] H. Kazemi, et al., "An ultra-low power integrated T/R module for space-based radar technology," 2004 IEEE Radar Conference, in press.